

A dark, monochromatic photograph of a server room with rows of server racks and overhead lights.

# SFP-10G23-BX10 Data Sheet

# 10GBASE-BX SFP+ 1270nmTX/1330nmRX 10km DOM Transceiver

SFP-10G23-BX10

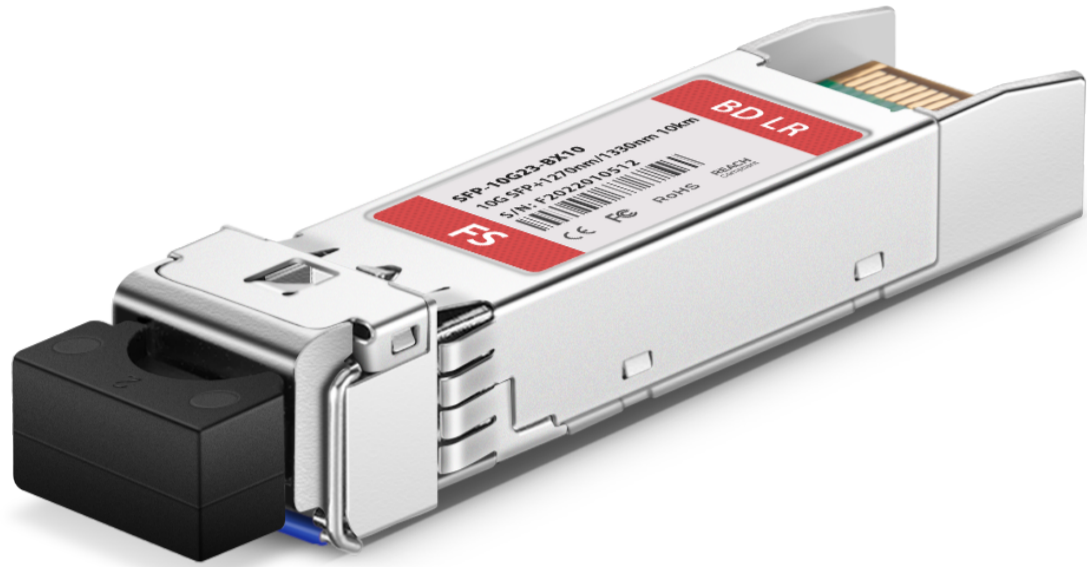

## Application

- 10GBASE-LR at 10.3125Gbps
- 10GBASE-LW at 9.953Gbps
- OBSAI rates 6.144 Gb/s, 3.072 Gb/s, 1.536 Gb/s, 0.768Gb/s
- CPRI rates 9.830 Gb/s, 7.373Gb/s, 6.144 Gb/s, 4.915 Gb/s, 2.458 Gb/s, 1.229 Gb/s, 0.614Gb/s
- Other Optical Links

## Features

- Operating data rate up to 11.3Gbps
- Two types:
  - A: 1270nm DFB Transmitter/ 1330nm Receiver
  - B: 1330nm DFB Transmitter/ 1270nm Receiver
- Power budget 9dB at least
- Single 3.3V Power supply and TTL Logic Interface
- LC Connector Interface
- Hot Pluggable
- Power Dissipation < 1.5W
- Built-in digital diagnostic functions, including optical power monitoring
- Commercial Temperature Range: 0~+70°C
- Compliant with SFP+ MSA Specification SFF-8431
- Compliant with IEEE 802.3ae 10GBASE-LR
- Compliant with IEEE 802.3ae 10GBASE-LW

- Compliant with IEEE 802.3cp

## Description

The SFP-10G-BX series single mode transceiver is small form factor plug module for duplex optical data communications such as 10GBASE-LR/LW defined by IEEE 802.3ae. It is with the SFP+ 20-pin connector to allow hot plug capability.

The SFP-10G-BX module is designed for single mode fiber and operates at nominal wavelength of 1270nm; SFP-10G-BX module is designed for single mode fiber and operates at a nominal wavelength of 1330nm. The transmitter section uses a multiple quantum well DFB, which is class 1 laser compliant according to International Safety Standard IEC-60825.

The receiver section uses an integrated InGaAs detector preamplifier (IDP) mounted in an optical header and a limiting post-amplifier IC.

## Product Specifications

### I. General Specifications

Parameter	Symbol	Min	Typ.	Max	Unit
Bit Rate	BR		10.3125	11.3168	Gb/s
Max. Supported Link Length	L <sub>max</sub>			10	km

### II. Absolute Maximum Ratings

Parameter	Symbol	Min	Max	Unit
Storage Temperature	T <sub>s</sub>	-40	+85	°C
Supply Voltage	V <sub>cc</sub>	-0.5	3.6	V

### III. Electrical Characteristics

Parameter	Symbol	Min	Typ.	Max	Unit	Ref.
Power Supply Voltage	V <sub>cc</sub>	3.15	3.3	3.45	V	
Power Supply Current	I <sub>cc</sub>			430	mA	
Surge Current	I <sub>surge</sub>			+30	mA	
<b>Transmitter</b>						
CML Inputs (Differential)	V <sub>in</sub>	150		1200	mVpp	AC coupled inputs
Input Impedance (Differential)	Z <sub>in</sub>	85	100	115	ohms	R <sub>in</sub> > 100 kohms @ DC
Tx_DISABLE Input Voltage - High		2		V <sub>cc</sub> +0.3	V	
Tx_DISABLE Input Voltage - Low		0		0.8	V	
Tx_FAULT Output Voltage - High		2		V <sub>cc</sub> +0.3	V	I <sub>o</sub> = 400μA; Host V <sub>cc</sub>
Tx_FAULT Output Voltage - Low		0		0.5	C	I <sub>o</sub> = -4.0Ma
<b>Receiver</b>						
CML Outputs (Differential)	V <sub>out</sub>	350		700	mVpp	AC coupled outputs
Output Impedance (Differential)	Z <sub>out</sub>	85	100	115	ohms	
Rx_LOS Output Voltage - High		2		V <sub>cc</sub> +0.3	V	I <sub>o</sub> =400μA; Host V <sub>cc</sub>

Rx_LOS Output Voltage - Low		0		0.8		Io = -4.0Ma
MOD_DEF ( 2:0 )	V <sub>oH</sub>	2.5			V	With Serial ID
	V <sub>oL</sub>	0		0.5	V	

#### IV. Optical Characteristics

(1270nm DFB & PIN/TIA)

Parameter	Symbol	Min	Typ.	Max	Unit
Power Budget		9			dB
Data Rate		0.6	10.3125	11.3	Gbps
<b>Transmitter (Tx)</b>					
Centre Wavelength	$\lambda_c$	1260	1270	1280	nm
Spectral Width (-20Db)	$\Delta\lambda$			1	nm
Side Mode Suppression Ratio	$\lambda_c$	30			dB
Average Output Power*note1	P <sub>out, AVG</sub>	-8.2		0.5	dBm
Extinction Ratio	ER	3.5			dB
Average Power of OFF Transmitter				-30	dB
Average Power of OFF Transmitter	RIN			-128	dB/Hz
TX Disable Assert Time	t <sub>off</sub>			10	us
<b>Receiver (Rx)</b>					
Centre Wavelength	$\lambda_c$	1320		1340	nm
Sensitivity*note2	P <sub>IN</sub>			-14.4	dBm
Receiver Overload	P <sub>MAX</sub>	0.5			dBm
LOS De-Assert	LOS_D			-18	dBm
LOS Assert	LOS_A	-30			dBm

(1330nm DFB & PIN/TIA)

Parameter	Symbol	Min	Typ.	Max	Unit
Power Budget		9			dB
Data Rate		0.6	10.3125	11.3	Gbps
<b>Transmitter (Tx)</b>					
Centre Wavelength	$\lambda_c$	1320	1330	1340	nm
Spectral Width (-20Db)	$\Delta\lambda$			1	nm
Side Mode Suppression Ratio	SMSR	30			dB
Average Output Power*note1	P <sub>out, AVG</sub>	-8.2		0.5	dBm

Extinction Ratio	ER	3.5			dB
Average Power of OFF Transmitter				-30	dB
Average Power of OFF Transmitter	RIN			-128	dB/Hz
TX Disable Assert Time	t <sub>off</sub>			10	us
<b>Receiver (Rx)</b>					
Centre Wavelength	$\lambda_c$	1320		1280	nm
Sensitivity*note2	P <sub>IN</sub>			-14.4	dBm
Receiver Overload	P <sub>MAX</sub>	0.5			dBm
LOS De-Assert	LOS_D			-18	dBm
LOS Assert	LOS_A	-30			dBm

**Notes:**

1. Output is coupled into a 9/125um SMF.
2. Measured with worst ER, BER less than 1E-12 and PRBS2<sup>31</sup>-1 at 10.3125Gbps.

**V. Pin Description**

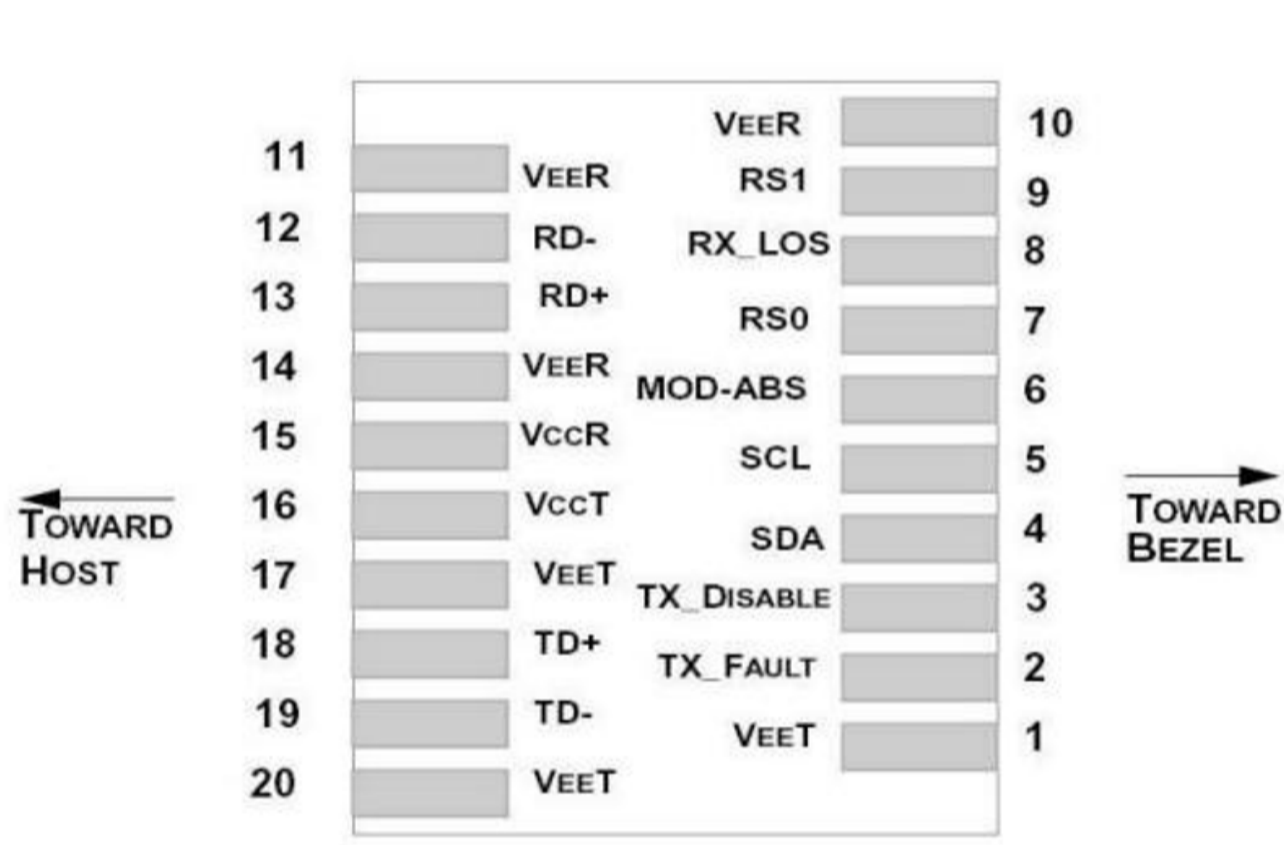

Pin Num.	Name	Function	Plug Seq.	Notes
1	VeeT	Transmitter Ground	1	Note 5
2	TX Fault	Transmitter Fault Indication	3	Note 1
3	TX Disable	Transmitter Disable	3	2, Module disables on high or open
4	SDA	Module Definition 2	3	2-wire Serial Interface Data Line.
5	SCL	Module Definition 1	3	2-wire Serial Interface Clock.
6	MOD_ABS	Module Definition 0	3	Note 3
7	RS0	RX Rate Select (LVTTTL).	3	Rate Select 0, optionally controls SFP+ module receiver. This pin is pulled low to VeeT with a >30K resistor..

8	LOS	Loss of Signal	3	Note 4
9	RS1	TX Rate Select (LVTTTL).	1	Rate Select 1, optionally controls SFP+ module transmitter. This pin is pulled low to VeeT with a >30K resistor.
10	VeeR	Receiver Ground	1	Note 5
11	VeeR	Receiver Ground	1	Note 5
12	RD-	Inv. Received Data Out	3	Note 6
13	RD+	Received Data Out	3	Note 6
14	VeeR	Receiver Ground	1	Note 5
15	VeeR	Receiver Power	2	3.3V ± 5%, Note 7
16	VccT	Transmitter Power	2	3.3V ± 5%, Note 7
17	VeeT	Transmitter Ground	1	Note 5
18	TD+	Transmit Data In	3	Note 8
19	TD-	Inv. Transmit Data In	3	Note 8
20	VeeT	Transmitter Ground	1	Note 5

**Notes:**

1. TX Fault is an open collector/drain output, which should be pulled up with a 4.7K – 10K $\Omega$  resistor on the host board. Pull up voltage between 2.0V and VccT/R+0.3V. When high, output indicates a laser fault of some kind. Low indicates normal operation. In the low state, the output will be pulled to <0.8V.
2. TX disable is an input that is used to shut down the transmitter optical output. It is pulled up within the module with a 4.7K – 10 K $\Omega$  resistor. Its states are: Low (0 – 0.8V): Transmitter on (>0.8, < 2.0V): Undefined High (2.0 – 3.465V): Transmitter Disabled Open: Transmitter Disabled.
3. Module Absent, connected to VeeT or VeeR in the module.
4. LOS (Loss of Signal) is an open collector/drain output, which should be pulled up with a 4.7K – 10K $\Omega$  resistor. Pull up voltage between 2.0V and VccT/R+0.3V. When high, this output indicates the received optical power is below the worst- case receiver sensitivity (as defined by the standard in use). Low indicates normal operation. In the low state, the output will be pulled to < 0.8V.
5. The module signal ground contacts, VeeR and VeeT, should be isolated from the module case.
6. RD-/+ : These are the differential receiver outputs. They are AC coupled 100 $\Omega$  differential lines which should be terminated with 100 $\Omega$  (differential) at the user SERDES. The AC coupling is done inside the module and is thus not required on the host board. The voltage swing on these lines will be between 350 and 700 Mv differential (175–350 Mv single ended) when properly terminated.
7. VccR and VccT are the receiver and transmitter power supplies. They are defined as 3.3V±5% at the SFP+ connector pin. Maximum supply current is 300Ma. Recommended host board power supply filtering is shown below. Inductors with DC resistance of less than 1 ohm should be used in order to maintain the required voltage at the SFP+ input pin with 3.3V supply voltage. When the recommended supply- filtering network is used, hot plugging of the SFP+ transceiver module will result in an inrush current of no more than 30Ma greater than the steady state value. VccR and VccT may be internally connected within the SFP+ transceiver module.
8. TD-/+ : These are the differential transmitter inputs. They are AC-coupled, differential lines with 100 $\Omega$  differential termination inside the module. The AC coupling is done inside the module and is thus not required on the host board. The inputs will accept differential swings of 150 – 1200 Mv (75 –600Mv single-ended).

**EEPROM :**

The serial interface uses the 2-wire serial CMOS EEPROM protocol defined for the ATMEL AT24C02/04 family of components. When the serial protocol is activated, the host generates the serial clock signal (SCL). The positive edge clocks data into those segments of the EEPROM that are not writing protected within the SFP+ transceiver. The negative edge clocks data from the SFP+ transceiver. The serial data signal (SDA) is bi-directional for serial data transfer. The host uses SDA in conjunction with SCL to mark the start and end of serial protocol activation. The memories are organized as a series of 8-bit data words that can be addressed individually or sequentially.

The Module provides diagnostic information about the present operating conditions. The transceiver generates this diagnostic data by digitization of internal analog signals. Calibration and alarm/warning threshold data is written during device manufacture. Received power monitoring, transmitted power monitoring, bias current monitoring, supply voltage monitoring and temperature monitoring all are implemented. If the module is defined as external calibrated, the diagnostic data are raw A/D values and must be converted to real world units using calibration constants stored in EEPROM locations 56 – 95 at wire serial bus address A2h. The digital diagnostic memory map specific data field define as following. For detail EEPROM information, please refer to the related document of SFF 8472 Rev 10.2.

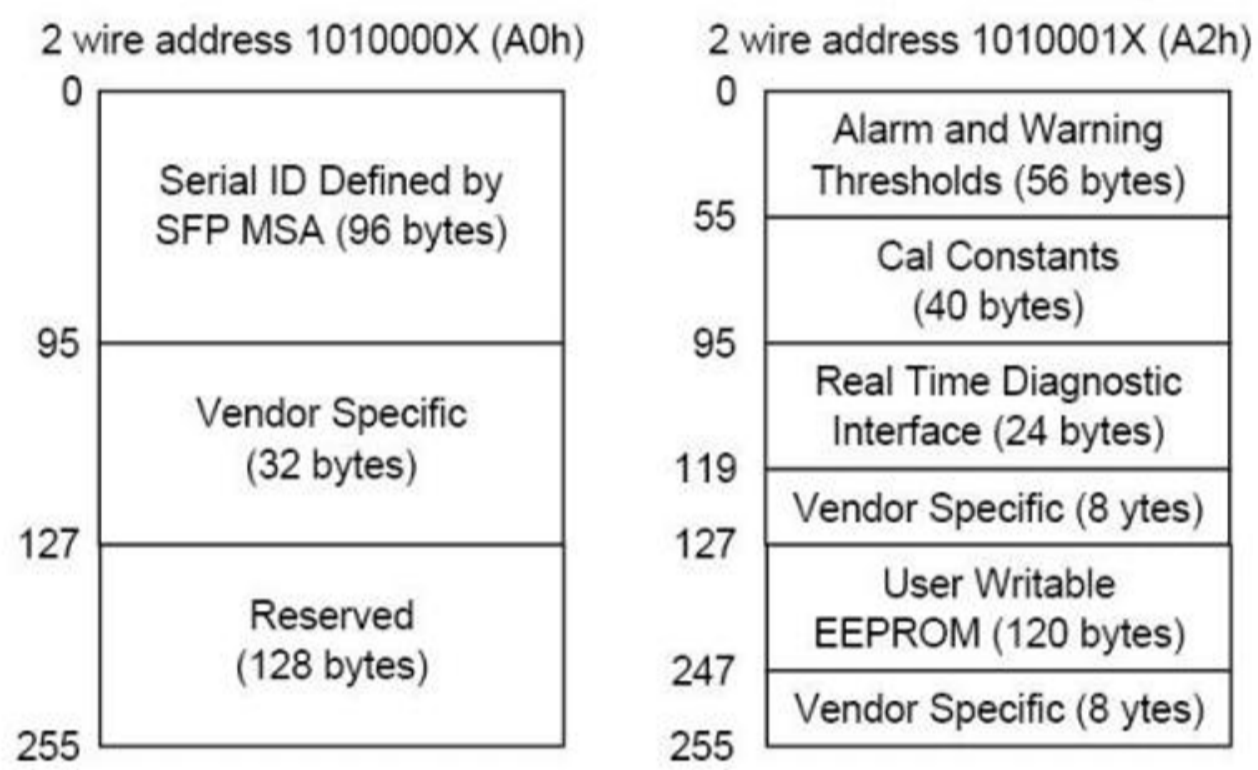

### VI. Recommend Circuit Schematic

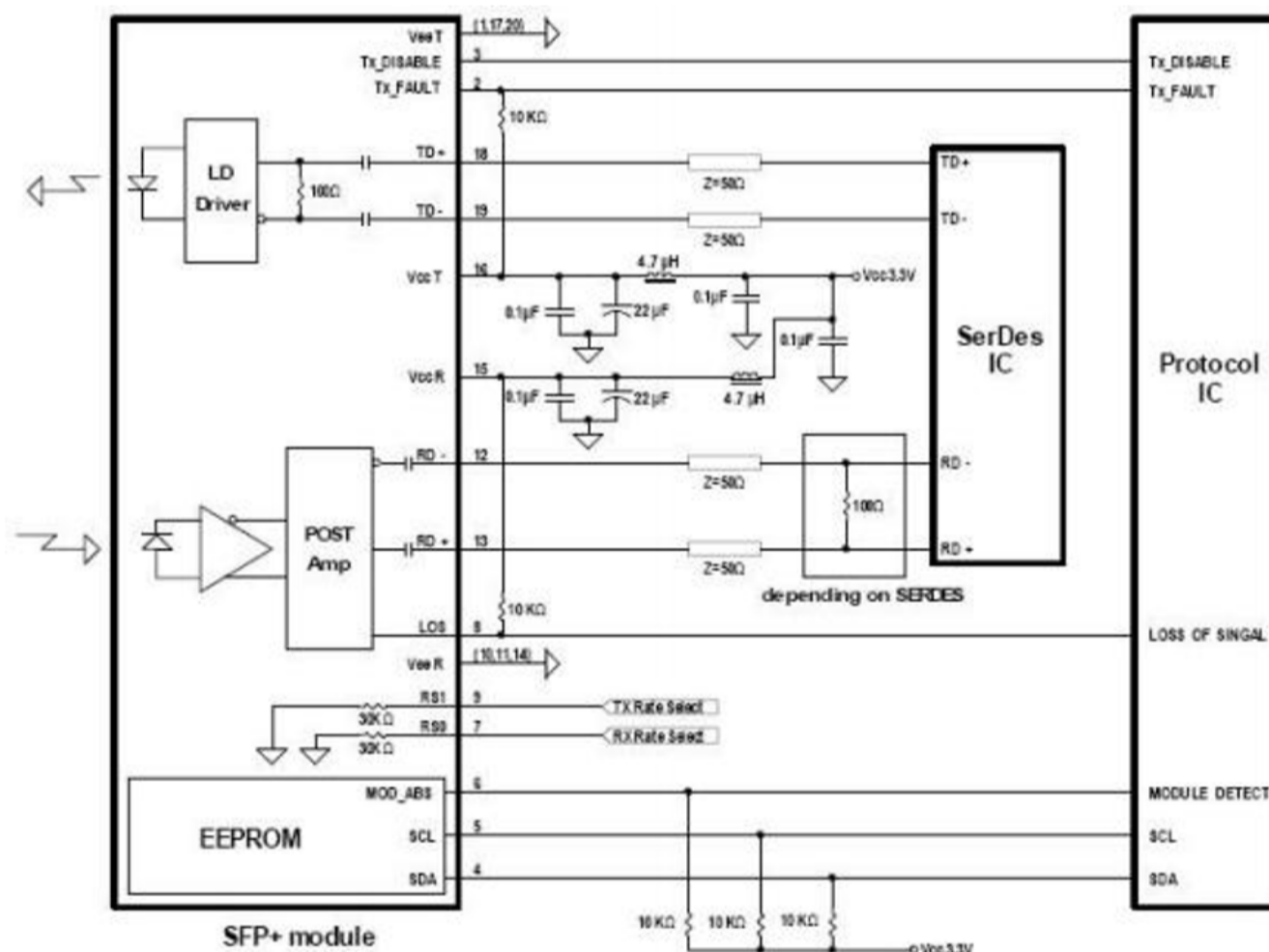

### VII. Mechanical Specifications

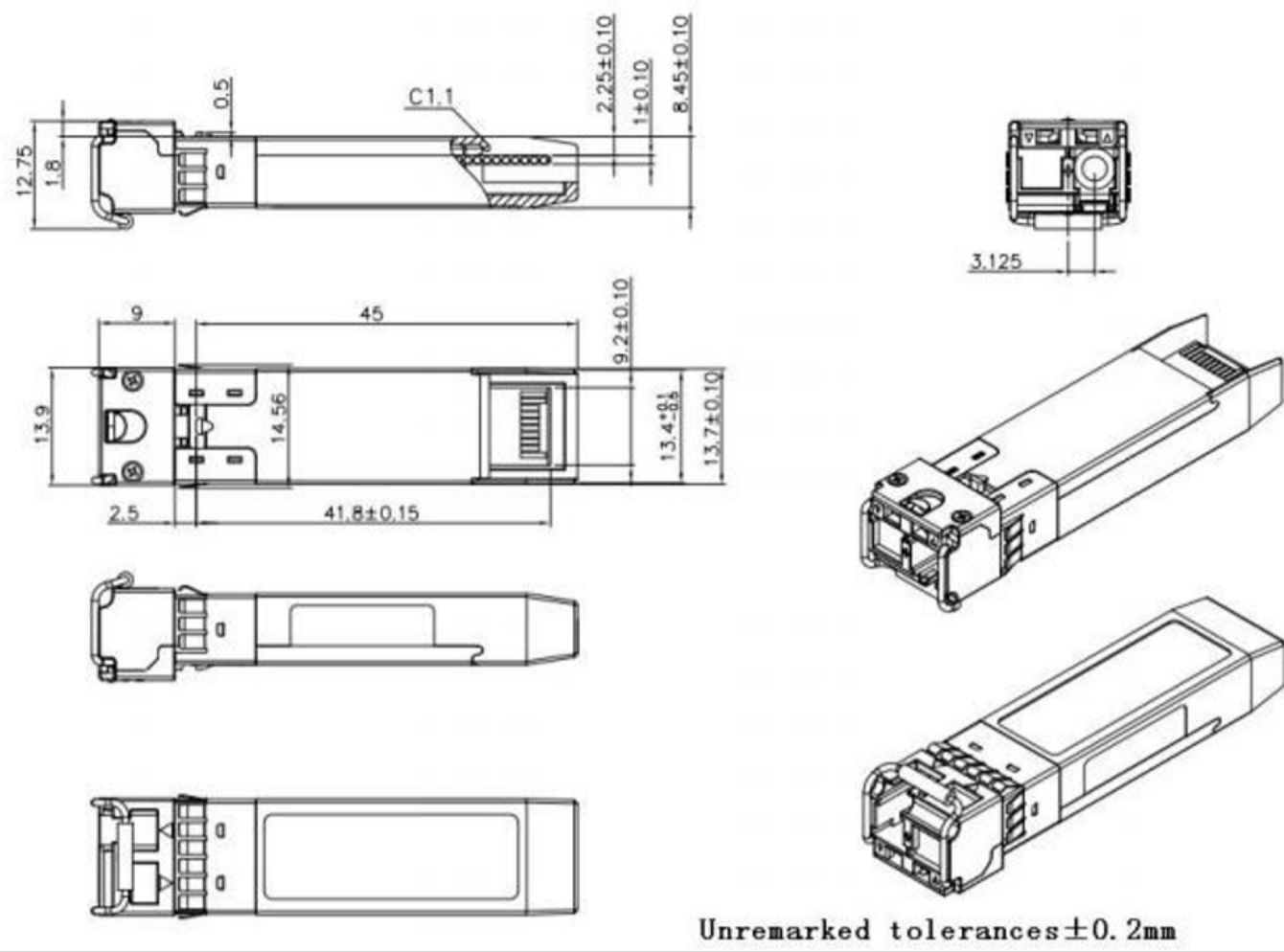

## Test Center

FS.COM transceivers are tested to ensure connectivity and compatibility in our test center before shipped out. FS.COM test center is supported by a variety of mainstream original brand switches and groups of professional staff, helping our customers make the most efficient use of our products in their systems, network designs and deployments.

The original switches could be found nowhere but at FS.COM test center, eg: Juniper MX960 & EX 4300 series, Cisco Nexus 9396PX & Cisco ASR 9000 Series, HP 5900 Series & HP 5406R ZL2 V3(J9996A), Arista 7050S-64, Brocade ICX7750-26Q & ICX6610-48, Avaya VSP 7000 MDA 2, etc.



Cisco ASR 9000 Series(A9K-MPA-1X40GE)



ARISTA 7050S-64(DCS-7050S-64)



Juniper MX960



Brocade ICX 7750-26Q



Extreme Networks X670V VIM-40G4X



Mellanox M3601Q



Dell N4032F



HP 5406R ZL2 V3(J9996A)



AVAYA 7024XLS(7002QQ-MDA)

## Test Assured Program

FS.COM truly understands the value of compatibility and interoperability to each optics. Every module FS.COM provides must run through programming and an extensive series of platform diagnostic tests to prove its performance and compatibility. In our test center, we care of every detail from staff to facilities—professionally trained staff, advanced test facilities and comprehensive original-brand switches, to ensure our customers to receive the optics with superior quality.



Our smart data system allows effective product management and quality control according to the unique serial number, properly tracking the order, shipment and every part.



Our in-house coding facility programs all of our parts to standard OEM specs for compatibility on all major vendors and systems such as Cisco, Juniper, Brocade, HP, Dell, Arista and so on.



With a comprehensive line of original-brand switches, we can recreate an environment and test each optics in practical application to ensure quality and distance.



The last test assured step to ensure our products to be shipped with perfect package.

## Order Information

Part Number	Description
<a href="#">SFP-10G23-BX10</a>	SFP+, BIDI, 10GBase, 1270TX/1330nmRX, SMF, 10km, LC, DOM
<a href="#">SFP-10G32-BX10</a>	SFP+, BIDI, 10GBase, 1330TX/1270nmRX, SMF, 10km, LC, DOM
<a href="#">SFP-10G23-BX20</a>	SFP+, BIDI, 10GBase, 1270TX/1330nmRX, SMF, 20km, LC, DOM
<a href="#">SFP-10G32-BX20</a>	SFP+, BIDI, 10GBase, 1330TX/1270nmRX, SMF, 20km, LC, DOM
<a href="#">SFP-10G23-BX40</a>	SFP+, BIDI, 10GBase, 1270TX/1330nmRX, SMF, 40km, LC, DOM
<a href="#">SFP-10G32-BX40</a>	SFP+, BIDI, 10GBase, 1330TX/1270nmRX, SMF, 40km, LC, DOM
<a href="#">SFP-10G23-BX60</a>	SFP+, BIDI, 10GBase, 1270TX/1330nmRX, SMF, 60km, LC, DOM
<a href="#">SFP-10G32-BX60</a>	SFP+, BIDI, 10GBase, 1330TX/1270nmRX, SMF, 60km, LC, DOM
<a href="#">SFP-10G23-BX80</a>	SFP+, BIDI, 10GBase, 1270TX/1330nmRX, SMF, 80km, LC, DOM

<a href="#">SFP-10G32-BX80</a>	SFP+, BIDI, 10GBase, 1330TX/1270nmRX, SMF, 80km, LC, DOM
<a href="#">SFP-10G45-BX80</a>	SFP+, BIDI, 10GBase, 1490TX/ 1550nmRX, SMF, 80km, LC, DOM
<a href="#">SFP-10G54-BX80</a>	SFP+, BIDI, 10GBase, 1550TX/ 1490nmRX, SMF, 80km, LC, DOM
<a href="#">SFP-10G45-BX100</a>	SFP+, BIDI, 10GBase, 1490TX/ 1550nmRX, SMF, 100km, LC, DOM
<a href="#">SFP-10G54-BX100</a>	SFP+, BIDI, 10GBase, 1550TX/ 1490nmRX, SMF, 100km, LC, DOM

**Note:**

1. 10G SFP+ transceiver module is individually tested on corresponding equipment such as Cisco, Arista, Juniper, Dell, Brocade and other brands, and passes the monitoring of FS.COM intelligent quality control system.



### Delaware, United States

Address: Delaware: 380 Centerpoint Blvd, New Castle, DE 19720, United States  
Email: US@fs.com  
Tel: +1 (888) 468-9910

### Germany

Address: Röntgenstraße 18, 85757 Karlsfeld, Germany  
Email: DE@fs.com  
Tel: +49 (0) 8131 377 3008

### Australia

Address: 57-59 Edison Rd, Dandenong South, VIC 3175, Australia  
Email: AU@fs.com  
Tel: +61 3 5909 9990

### Japan

Address: JS Progress Building 5F, 4-1-23, Heiwajima, Ota Ku, Tokyo, 143-0006, Japan  
Email: JP@fs.com  
Tel: +81-3-6897-9438

### California, United States

Address: California: 15241 Don Julian Rd, City of Industry, CA 91745, United States  
Email: US@fs.com  
Tel: +1 (888) 468-9910

### United Kingdom

Address: Unit 8, Urban Express Park, Union Way, Aston, Birmingham B6 7FH, United Kingdom  
Email: UK@fs.com  
Tel: +44 (0) 121 726 4775

### Singapore

Address: 7002 ANG MO KIO AVENUE 5 #05-02 Singapore 569914  
Email: SG@fs.com  
Tel: +65 31381992



FS has several offices around the world. Addresses, phone numbers are listed on the FS Website at [https://www.fs.com/contact\\_us.html](https://www.fs.com/contact_us.html). FS and FS logo are trademarks or registered trademarks of FS in the U.S. and other countries.